

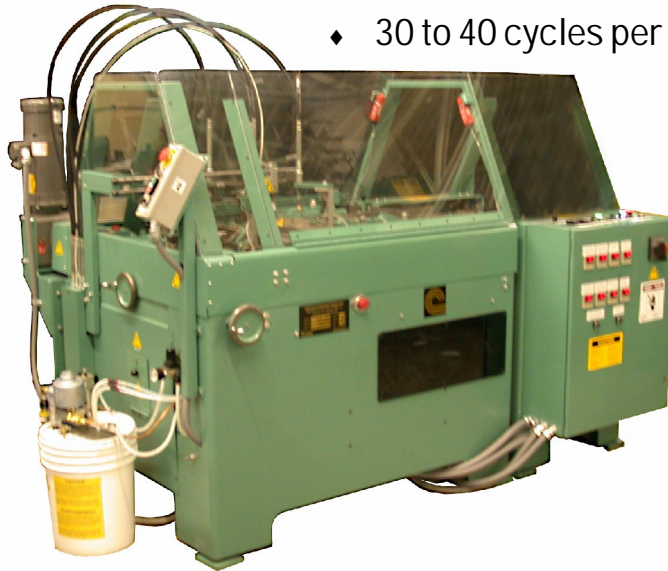

# CRATHERN MACHINERY GROUP, INC.

- ◆ Beaded edges for extra rigidity
- ◆ Square solvent sealed corners
- ◆ 30 to 40 cycles per minute



- ◆ Set-up time 30 minutes
- ◆ Final tune-up time 15 minutes

**CMG** Transparent Box  
Machinery

Model: 4028

# Model: Transparent Boxmaking 4028 Plastic Box

# SPECIFICATIONS

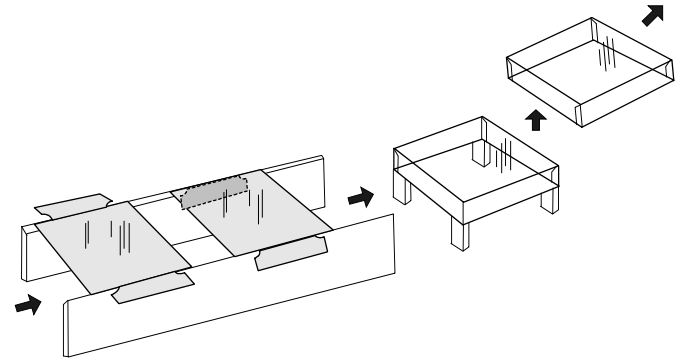
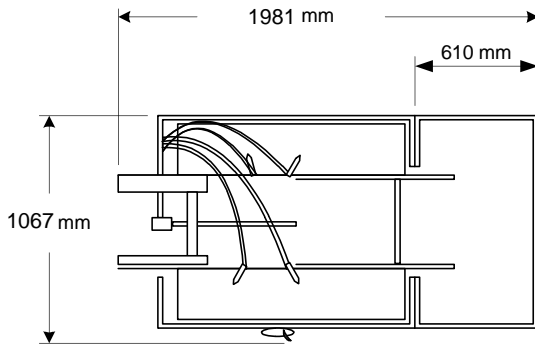

## Size Range:

BOX: (Dependent on blank size)

Min. 76 x 25 x 10 mm

Max. 405 x 280 x 12.7 mm or 405 x 203 x 76 mm

BLANK:

Min. 95 x 45 mm

Max. 558 x 355 mm\*\*

## Material Thickness:

0.12 to 0.25 mm

## Production Speed:

Up to 40 cycles per minute

## Floor Space:

2125 x 1500 x 1752 mm

## Discharge Height:

980 to 1045 mm

## Energy Requirements:

MOTORS:

Driving 1 HP; Vacuum Pump 3/4 HP

ELECTRICAL:

7.6 kva, 3 Phase, 50/60 Hz

Any Voltage from 208 to 600

Customer to provide CMG with voltage requirements

AIR:

225 L/min @ 5.6 kg/cm<sup>2</sup> (6 bar)

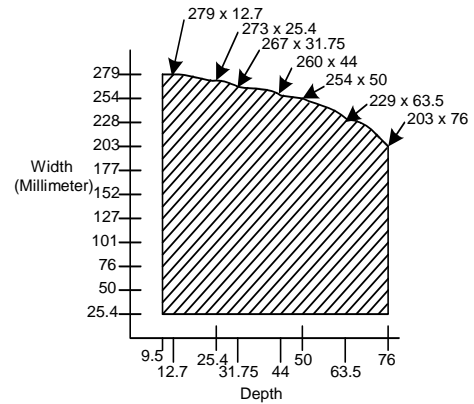

The above chart gives the width and depth range of the 4028 up to 406 mm long. Any size outside the hatched area cannot be made on this machine

## Shipping:

WEIGHT:

Model SVF-XL: 1225 kg

Model 4028: 1020 kg

\*\*All width boxes up to 245 mm regardless of length, may be fed automatically. When width exceeds 245 mm manual assistance in feeding may be required depending upon depth.

Advertised machine production speeds and product quality are based on materials selected by Crathern or actual production reported by our customers. The selection of materials used by each customer is their sole responsibility and will directly effect the product quality and output of the machine.

Due to continuous product improvements, we reserve the right to change or discontinue specifications, designs and manufacturing locations shown in this brochure without notice and without incurring obligation.

date of issue 07/12

## FOR DETAILS CONTACT:

Corporate Headquarters: New Hampshire ☎: (603) 341-0444

☎: (800) 746-4111 (USA ONLY)

Web Site: [www.crathern.com](http://www.crathern.com)

Branches: Belgium ☎: 32.(0)9.369.34.55

Italy ☎: 39 (02) 6192287 or 6191637

